

SCHRÖDER
GROUP

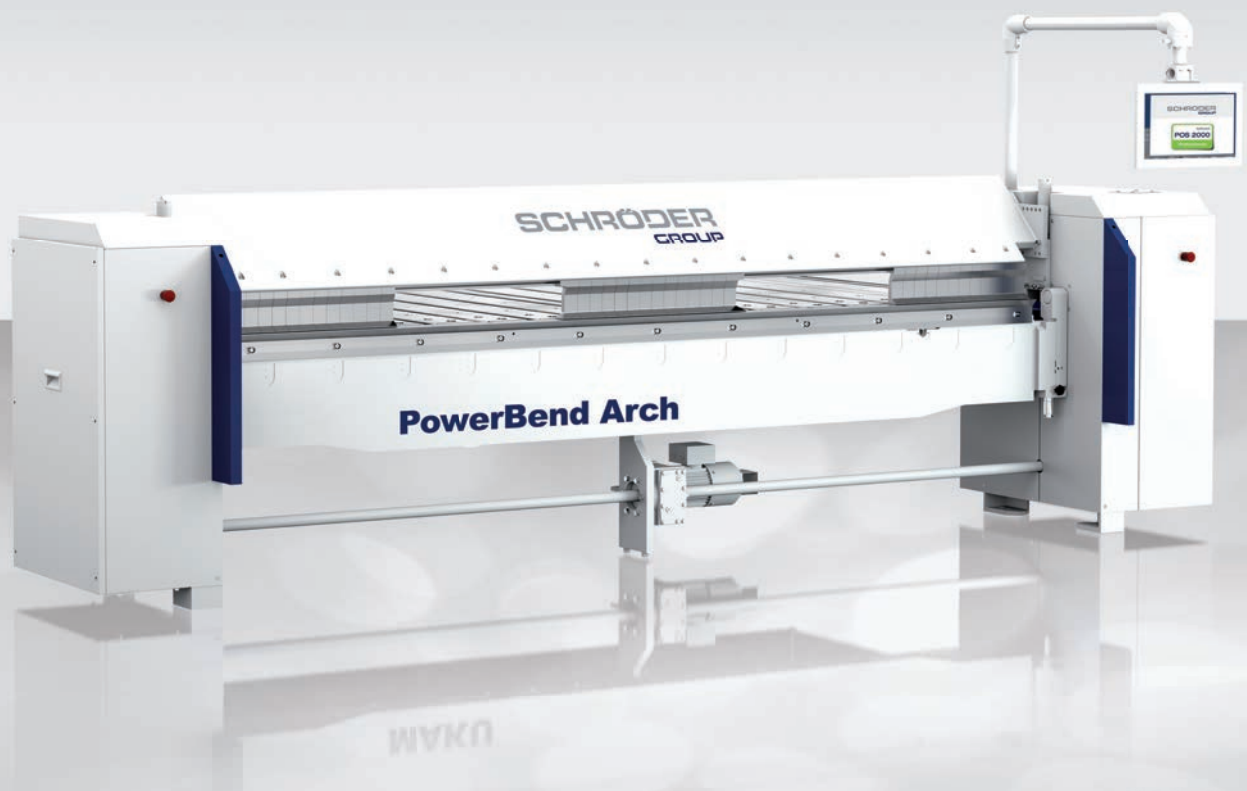

FOLDING MACHINE
PowerBend Architectural

Folding machine PowerBend Architectural

The versatile motorized folding machine PowerBend Architectural (PBA) is perfect for sheet metal processing in small- and medium-sized workshops.



PowerBend Architectural

Work. length x Sheet thickn. (400 N/mm ²)	3,220 x 2.0 mm
---	----------------

In the standard version the PowerBend Architectural is equipped with the new Classic Bend control - this makes it an extremely versatile machine.



Crowning device for folding beam: manual central crowning device (not in combination with cranked folding blades).

The motorized folding machine PowerBend Architectural (PBA) convinces with its robust and stable construction. This folding machine is designed to meet the demands of sophisticated handicraft businesses. Its flexibility through applications up to 2.0 mm steel is the result of Hans Schröder Maschinenbau's decades of experience in industrial sheet metal folding. The PBA offers optimum precision, longevity and stability. It was engineered using extremely rigid machine bodies according to state-of-the-art technology.

This versatile machine is a safe investment into motorized sheet metal processing - and in the future of your company. With the PBA you get the know-how from our industrial machines for your workshop.

Folding machines from Schröder are extremely long-lasting, low-maintenance and aimed at continuous operation with same high quality. You are able to produce faster and to reduce unit costs. You can not only increase your competitiveness through quick small series production but also thanks to demanding single orders in the short-term and with maximum precision.

The path-breaking electronic software control, that already masters radius bending in its standard, can be programmed quickly with no computer skills. Anyone can program with the Classic Bend, making it the perfect machine for a wide array of production requirements. The PBA is the motorized folding machine for increased efficiency in your production.

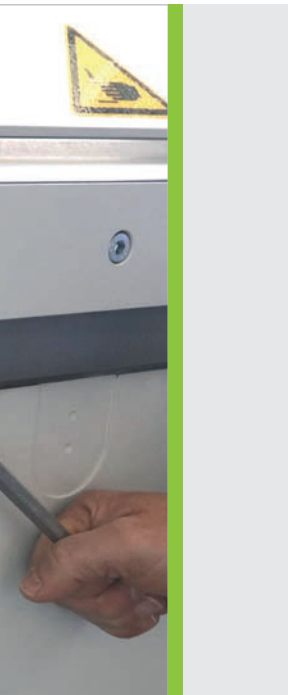

Standard equipment	
Software control	<ul style="list-style-type: none"> – Positioning control Classic Bend, touchscreen monitor turnable on switch cabinet – Radius function
Clamping beam	<ul style="list-style-type: none"> – 45° clamping beam with clearance 65 mm – Drive: middle motor 0,75 kW (converter-controlled, eccentric drive) – Clamping beam stroke: 150 mm – Clamping pressure adjustment via handwheel (without tool) – Tinsmith blade 20° (WZS 080) , R 1/1.5 ca. 700 N/mm², clearance 12 mm for hems, foot width 24 mm; optionally sharp-nose blade 20°, foot width 36 mm, directly screwed to clamping beam
Folding beam	<ul style="list-style-type: none"> – Drive: 1.5 kW (converter-controlled) – Manual folding beam adjustment: 30 mm – Folding blades (WZS 100) 15 mm and 25 mm, ca. 700 N/mm²
Bottom beam	<ul style="list-style-type: none"> – Bottom beam blade (WZS 270), one-piece, ca. 700 N/mm², from 30 mm: 8 mm lowered depending on chosen gauge <ul style="list-style-type: none"> – without finger grooves – with finger grooves 6 mm or optionally 10 mm
Others	<ul style="list-style-type: none"> – Foot switch – Anchor plates incl. dowels

Special equipment																			
Software control	– POS 2000 Professional graphic control on swivelling arm																		
Clamping beam	<ul style="list-style-type: none"> – One-stage clamping beam drive for tool height 130 mm incl. clamping and adapter (clamping rail from standard configuration dropped) – Multi-stage clamping beam drive for two different tool heights incl. clamping rail WZS 010 (Clamping beam rail from standard configuration dropped) 																		
Folding beam	<ul style="list-style-type: none"> – Folding beam moved to the back incl. cranked folding blades 15 and 25 mm, ca. 700 N/mm² (WZS 130). Not in combination with crowning device, folding blades from standard configuration are dropped – Manual crowning device, central (not in combination with cranked folding blades) 																		
Table and back gauge	<ul style="list-style-type: none"> – Sheet support table 1,000 mm (without gauge), optionally with steel balls in table – Back gauge package: <table border="1" data-bbox="570 1544 1203 1771"> <thead> <tr> <th>Classic Bend</th> <th>POS 2000 Professional</th> <th>POS 2000 Professional incl. tapered bending</th> </tr> </thead> <tbody> <tr> <td colspan="3">Back gauge, motor. 5 – 1,000 mm or 10 – 1,000 mm</td> </tr> <tr> <td colspan="3">12 gauge fingers</td> </tr> <tr> <td colspan="3">removable sheet support plates; retractable to 265 mm or rather 300 mm</td> </tr> <tr> <td></td> <td>POS 2000 Professional control</td> <td>POS 2000 Professional incl. tapered bending</td> </tr> <tr> <td colspan="3">All drives converter-controlled</td> </tr> </tbody> </table> – Back gauge motorized 1,500 mm with 2 gauge sectors incl. pneumatically lowerable gauge fingers – Pneumatic lowerable gauge fingers – Two gauge fingers for tapered bending, adjustment range 5 mm – Two additional gauge fingers for tapered bending, adjustment range 5 mm; pneumatically lowerable (only in combin. with the option pneumatically lowerable gauge finger) 	Classic Bend	POS 2000 Professional	POS 2000 Professional incl. tapered bending	Back gauge, motor. 5 – 1,000 mm or 10 – 1,000 mm			12 gauge fingers			removable sheet support plates; retractable to 265 mm or rather 300 mm				POS 2000 Professional control	POS 2000 Professional incl. tapered bending	All drives converter-controlled		
Classic Bend	POS 2000 Professional	POS 2000 Professional incl. tapered bending																	
Back gauge, motor. 5 – 1,000 mm or 10 – 1,000 mm																			
12 gauge fingers																			
removable sheet support plates; retractable to 265 mm or rather 300 mm																			
	POS 2000 Professional control	POS 2000 Professional incl. tapered bending																	
All drives converter-controlled																			
Safety and Others	<ul style="list-style-type: none"> – Safety laser system directly on the bending line, more information see p. 4 – Add. equipment for 2-man-operation in accordance with accident prevention rules – Foot switch on rail for lateral movement – Cutting device for max. sheet thickness 0.8 mm and guide rail – Tool options see p. 7 																		

Dimensions and technical data



PBA	3,200 x 2.0
Working length (a)	3,220 mm
Sheet thickness (400 N/mm ²)	2.0 mm
Machine length (b)	4,475 mm
Length of working area (c)	3,620 mm
Machine height (d)	1,255 mm
Working height (e)	870 mm
Weight (ca.)	2,700 kg
Machine width	
Without gauge	995 mm
Sheet support table 1,000 mm	1,970 mm
Back gauge, motorized 1,000 mm resp. 1,500 mm (f)	1,970 mm
Clamping beam	
Stroke	150 mm
Drive power	0.75 kW
Speed	65 mm/sec (85 mm/sec)
Folding beam	
Adjustment	30 mm
Drive power	1.5 kW
Speed	65°/sec (90°/sec)
Back gauge	
Speed	300 mm/sec

Thanks to the set back folding beam with a cranked folding blade trapezoidal sheets and profiles with standing seams are very easy to bend.

All specifications are considered as guidelines and may be subject to changes at any time.



Fully speed – maximum safety: Laser system directly on the bending line

The laser system directly on the bending line incl. box bending function is a safety system that protects the danger zone between the clamping beam and the folding beam with three light beams. It is installed on both sides and enables work to be carried out without a pre-stop, as the clamping beam can move at full speed to the clamping position. If the safety zone is entered, the machine stops immediately or continues in safety mode at reduced speed.

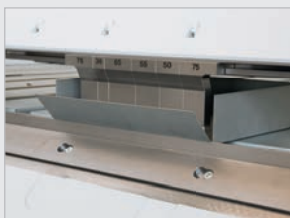

Practical tools and recessed folding beam

The tool system WZS 010 for the PBA can be acquired optionally and has already been used for many Schröder machines for a long time. The segmented goat's foot tools enable bending up to 110 mm high boxes. Likewise, a set back folding beam with a cranked folding blade enables new possibilities such as the bending of top-hat and standing seam profiles or trapezoidal sheets.



Tapered bending

The PBA is also available with a 2 axis back gauge. No matter whether you want to bend parallel or tapered! We develop solutions to facilitate your work. So get your PBA and break new grounds!

Dimensions: PBA with Classic Bend control

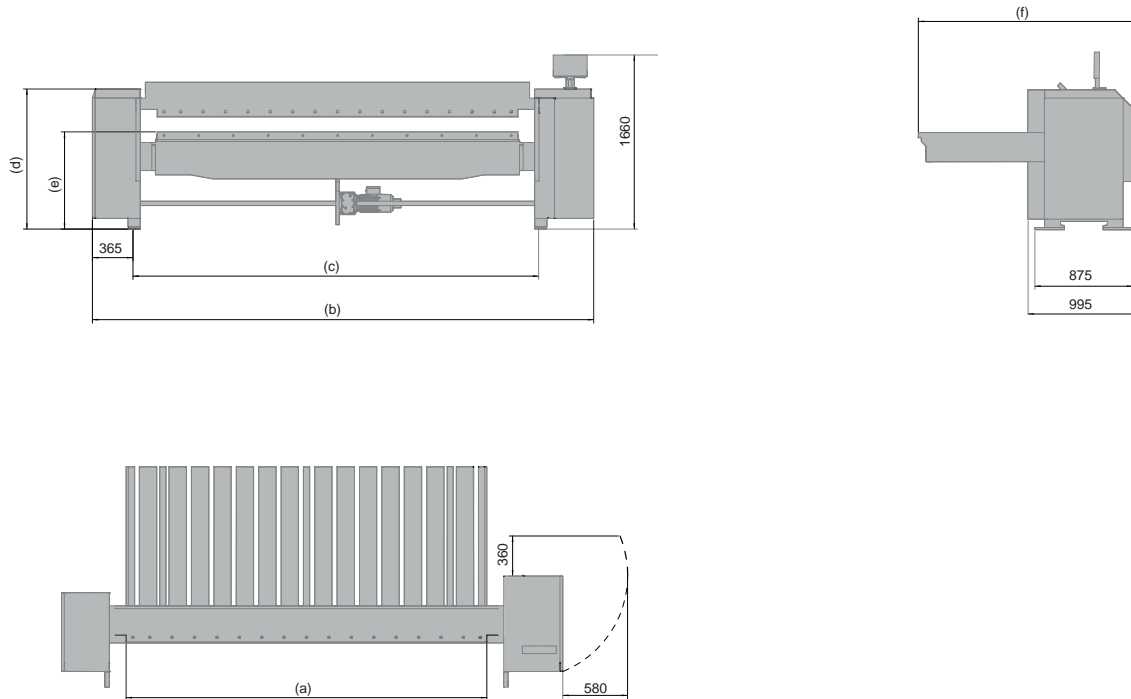

Dimensions: PBA with POS 2000 Professional control

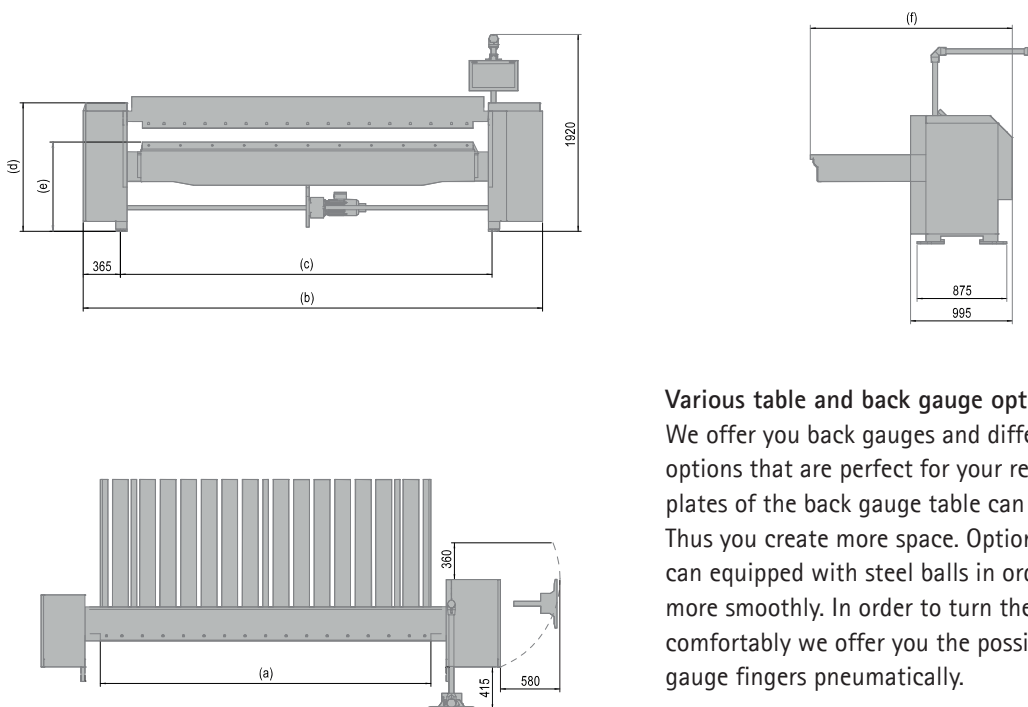

Various table and back gauge options

We offer you back gauges and different sheet support table options that are perfect for your requirements. The support plates of the back gauge table can be retracted easily by hand. Thus you create more space. Optionally the back gauge table can be equipped with steel balls in order to position the sheet more smoothly. In order to turn the sheet on the table more comfortably we offer you the possibility to lower the back gauge fingers pneumatically.

Software control



Highlights

- Bending programs are stored in folder structures
- Icon based programming
- Possibility of incremental step programming
- Position measurement system
- Separate axis correction for each step
- Bending list with current bend highlighted
- Scribe bending
- Piece counter
- Foot pedal display

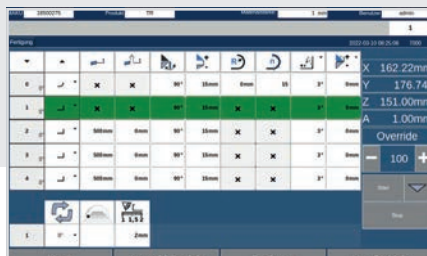

Simple symbols and alphanumeric data describes the bending program.



Highlights

- PC touchscreen control on swivelling arm
- Windows operating system
- Extensive profile catalog, unlimited expansion possible
- Automatic cut calculation
- Material and tool library
- True-to-size bending simulation
- Zoom function
- Speed of the CNC axis infinitely variable
- Radius function

Options

- External programming (PC-Version)



Above: Standard bending programs are available in the product selection menu. Below: The software shows the processing steps beforehand.

Tools

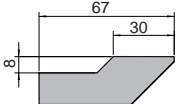
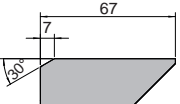
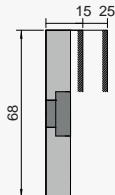
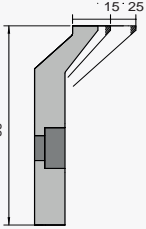
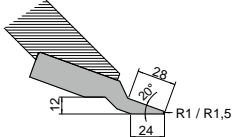
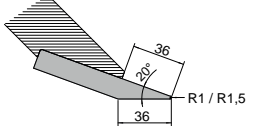
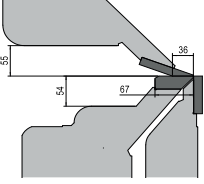
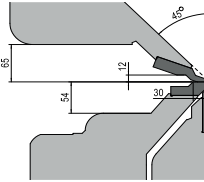
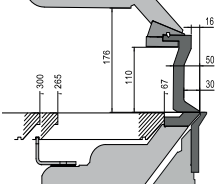
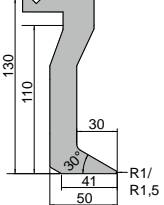
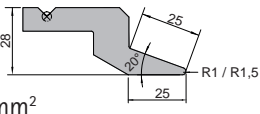
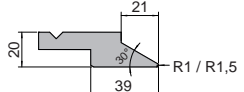
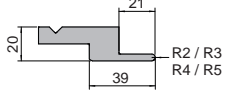
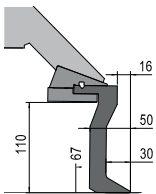
Tools	Standard	Option
<p>Bottom beam tools one-piece, ca. 700 N/mm², WZS* 270</p>	<ul style="list-style-type: none"> Bottom beam blade one-piece from 30 mm: 8 mm lowered without finger grooves with finger grooves 6 mm or optionally 10 mm 	<ul style="list-style-type: none"> Bottom beam blade one-piece without gradation without finger grooves with finger grooves 
<p>Folding beam tools</p>	<p><i>Folding beam tools WZS 100</i> ca. 700 N/mm²</p> <ul style="list-style-type: none"> Folding blade one-piece directly screwed, 15 and 25 mm, 68 mm high 	<p><i>With folding beam moved to the back:</i> <i>Folding beam tools WZS 130</i> ca. 700 N/mm²</p> <ul style="list-style-type: none"> Folding blades cranked 15 and 25 mm <p>Not in combination with crowning device, folding blades from standard configuration are dropped</p> 
<p>Clamping beam tools</p>	<p><i>Clamping beam tools WZS 080</i> hardened ca. 700 N/mm², directly screwed</p> <ul style="list-style-type: none"> Tinsmith blade one-piece 20°, R 1/1,5/3, clearance 12 mm, foot width 24 mm, Sharp nose blade one-piece 20°, R 1/1,5/3, foot width 36 mm     	<p><i>Clamping beam tools WZS 010</i> for clamping rail</p> <ul style="list-style-type: none"> Goat's foot blade 30°, R1 or R1,5, 130 mm high, clearance 30 mm, foot width 50 mm, segmented incl. corner parts, ca. 1100 N/mm² Tinsmith blade one-piece, 20°/30°, sharp, R1 or R1,5, clearance 8 mm, foot width 25 mm, ca. 700 N/mm² Sharp nose blade one-piece, 20°, sharp, R1 or R1,5 ca. 700 N/mm² Radius blade R2/3/4/5, ca. 700 N/mm²     <p>Tool clamping for WZS 010</p>  <ul style="list-style-type: none"> Sharp nose blade, tinsmith-, or radius blade divided incl. clamping rail divided (only in combination with clamping beam package) <p>(add. price for tinsmith-/sharp nose blade ca. 1100 N/mm²)</p>

* WZS = Tool system



Schröder Group

The Schröder Group consists of Hans Schröder Maschinenbau GmbH, which is located in Wessobrunn, Germany, SCHRÖDER-FASTI Technologie GmbH, located in Wermelskirchen, Germany and the SMU GmbH, located in Leinburg-Weißenbrunn.

Founded in 1949, Hans Schröder Maschinenbau GmbH unifies traditional and modern approaches in machine building: Successfully managed as a quality and customer-oriented, family-owned company, Hans Schröder Maschinenbau is specialized in the development of modern machine concepts for bending and cutting sheet metal.

The successful integration of the Fasti Company in 2006 and its worldwide presence make the Schröder Group one of today's leading providers of machines for bending, cutting, beading, flanging, and circular bending all types of sheet metal. The company's precision machines range from proven solutions for craftsmen to innovative, high-performance machines for automatic industrial production processes. 2021 the Schröder Group was expanded by the tool manufacturer SMU GmbH. Overall, the Schröder Group currently employs more than 300 people at various locations at home and abroad.

All information provided as a guide only and may be subject to change at all times.
HSM 260618EN

More information, pictures and videos
PBA



Hans Schröder Maschinenbau GmbH
Feuchten 2 | 82405 Wessobrunn-Forst | Germany
T +49 8809 9220-0 | F +49 8809 9220-700
E info@schroedergroup.eu
www.schroedergroup.eu

SCHRÖDER
GROUP