

HS – the effort-saving manual shear

The eccentric shear HS will be used for nearly all cutting requirements. Ridge-free, distortion-free and nearly burr-free cuttings are the typical characteristics of this shear.



Manual shear HS



Telescope sheet shute incl. stacking function

Standard equipment HS	
Telescopic support table [1]	
Angle gauge, left and right with inlaid scale [2]	
Milled grooves every 10 mm along the table, parallel to the blades [3]	
Hold-down device with hard rubber rail to protect polished sheets [4]	
Manual back gauge 500 mm [6]	
All-steel blade, double-edged	

Special equipment HS	
Back gauge	<ul style="list-style-type: none"> - Manual back gauge 750 mm - Manual back gauge 750 mm adjustable from the front with digital readout - Mechanical sheet support for manual back gauge 750 mm without sheet shute
Blades & Others	<ul style="list-style-type: none"> - Blades designed for stainless steel, instead of standard blades - Sheet shute to the front - Telescope sheet shute incl. stacking function - Sheet shute on wheels, 4 steering castors, 2 lockable (for cuttings up to max. 500 mm, up to max. 200 kg)

Gauge options facilitate handling

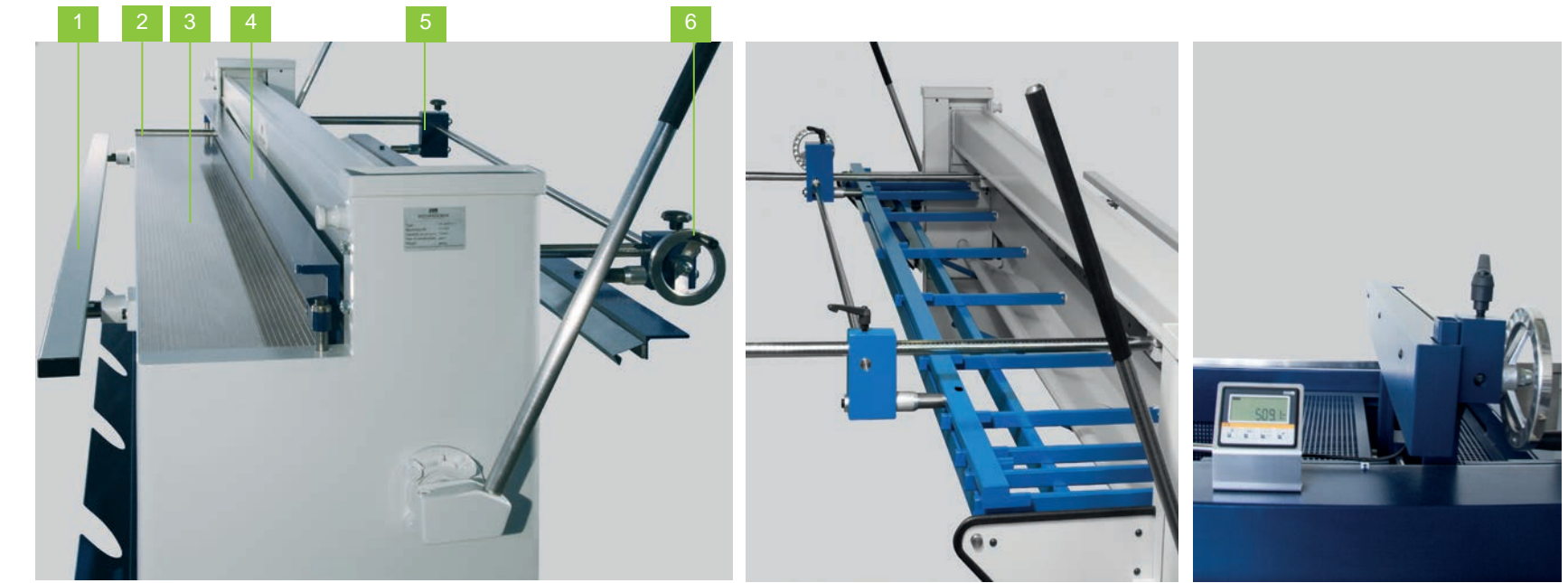

Manual back gauge with scale and handwheel adjustment [6] on the angle guides [5] for parallel and conical cuts.

Optional: Mechanical sheet support for manual back gauge 750 mm without sheet shute.

Optional: Manual back gauge 750 mm adjustable from the front with digital readout.

Standard – Type HS

Experience gathered over decades is reflected in the technology and design of this shear, which is capable of cutting almost any metal and non-metal materials. With the aid of new design techniques, we are able to offer a tried and tested product incorporating state-of-the-art technology.

Basic design

- Torsion-free rigid welded construction. Compact and well laid-out machine construction.
- Standard double-edged upper and lower blades of quality steel guarantee clean cuts without burrs for years to come.
- The low-friction overhead drive running in roller bearings ensures advantageous application of the levers.
- Flat cutting beam guides with robust and wear-resistant special sliding cover.

This maintenance free sliding cover ensures optimum guidance and clamping characteristics.

- Automatic hold-down device with specially injected neoprene tape holding down the parts carefully without damaging them.
- Angle gauge, left and right, with scale.
- Precision back gauge with handwheel adjustment on the angle guides for parallel and conical cuts

- All moving main drive parts run in roller bearings and are maintenance and wear-free.
- A telescope supports the cutting beam return, making for virtually effortless cutting.
- The variably extendable sheet support table ensures safe depositing of large-sized plates.

The additional features of the HS ensure a convenient operation

We offer you a wide range of back gauge and integrated sheet support systems.

For example, this shear provides you optionally with a mechanic sheet support for the manual back gauge. This sheet support ensures that metal sheet parts can be guided precisely to the back gauge and after the cutting are transferred into one of the sheet shutes.

The sheet shute on wheels is suitable for cuttings with a length of maximum 500 mm and a working load of maximum 200 kg.

In order to ensure the most efficient operation, you can acquire the manual back gauge which is adjustable from the front and has a digital readout. With this option the operator does not need to walk around the machine as he can easily adjust the gauge directly from the front. Also here, the sheet support in connection with the sheet shute completes the system.



Sheet shute on wheels with 4 steering castors, 2 lockable.

Technical data and dimensions

Technical data	1,000 × 2,0	2,000 × 1.25	2,500 × 1.0	3,000 × 1.0
Working length/cutting length (a)	1,030 mm	2,030 mm	2,530 mm	3,030 mm
Sheet thickness 400 N/mm ²	2.0 mm	1.25 mm	1.0 mm	1.0 mm
Cutting angle	4.0°	2.2°	1.8°	1.5°
Weight	485 kg	660 kg	775 kg	920 kg
Outer dimensions				
(b)	1,120 mm	2,120 mm	2,620 mm	3,120 mm
(c)	1,196 mm	2,196 mm	2,696 mm	3,196 mm
(d)	1,440 mm	2,440 mm	2,940 mm	3,440 mm
Machine width				
Back gauge, manual 500 mm (e)	540 mm			
Back gauge, manual 750 mm (e)	790 mm			
Back gauge, manual, adjustable from the front 750 mm (f)	860 mm			

Weights are for standard HS (Manual gauge 500 mm)

All specifications are considered as guidelines and may be subject to changes at any time.

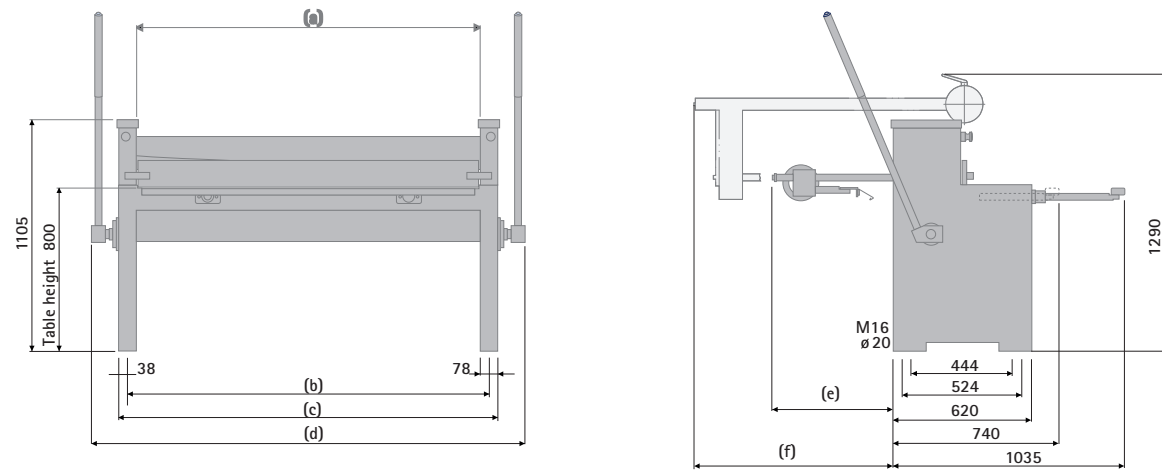

All dimensions in mm

Standard colours: RAL 7035 light grey, RAL 5003 sapphire blue. Special painting at an extra charge.



Schröder Group

The Schröder Group consists of Hans Schröder Maschinenbau GmbH, which is located in Wessobrunn, Germany, and SCHRÖDER-FASTI Technologie GmbH, which is located in Wermelskirchen, Germany.

Founded in 1949, Hans Schröder Maschinenbau GmbH unifies traditional and modern approaches in machine building: Successfully managed as a quality and customer-oriented, family-owned company, Hans Schröder Maschinenbau is specialized in the development of modern machine concepts for

bending and cutting sheet metal.

The successful integration of the Fasti Company in 2006 and its worldwide presence make the Schröder Group one of today's leading providers of machines for bending, cutting, beading, flanging, and circular bending all types of sheet metal. The company's precision machines range from proven solutions for craftsmen to innovative, high-performance machines for automatic industrial production processes. Overall, the Schröder Group currently employs more than 270 people at various locations at home and abroad.



All information provided as a guide only and subject to change at all times.
HSM 210216EN

Hans Schröder Maschinenbau GmbH
Feuchten 2 | 82405 Wessobrunn-Forst | Germany
T +49 8809 9220-0 | F +49 8809 9220-700
E info@schroedergroup.eu
www.schroedergroup.eu

SCHRÖDER
GROUP

MANUAL SHEAR
HS