

FOLDING MACHINE
MAK 4

The motorized folding machine MAK 4

The MAK 4 can be described as a already for a long time well-established motorized folding machine at Schröder. With a maximal working length of 4000 mm and a maximum bending capacity of 6,0 mm steel sheet, the giant is designed for a hard and double shift day.



Motorized folding machine MAK 4 with POS 2000 Professional control software as standard



The lowerable folding beam is necessary to bend bigger radii precisely.

The MAK 4 is the previous model of the Evolution series MAK 4 Evolution and SPB Evolution. This machine combines the long-term experiences of metal forming with state-of-the-art technology.

The Schröder software POS 2000 Professional makes it possible to bend precise roundings via a Step-Radius-Bending method using the clamping beam that presses the sheet against the bottom- and the folding beam - the high dimensional accuracy of the bending results are only one advantage that this machine offers.



Standard equipment	
Software control	<ul style="list-style-type: none"> - Graphic control POS 2000 Professional on swivelling arm with positioning gauge 10 - 1000 mm incl. sheet support table - Radius function
Clamping beam	<ul style="list-style-type: none"> - Sharp nose blade 30°, R 1.5 surface-treated (phosphated) - Clamping beam with recirculated ball screws - Tool clamping device, hydraulic
Folding beam	<ul style="list-style-type: none"> - Folding blade 42 mm, divided, surface-hardened (nitrated) - Folding beam drive, bilateral - Motorized folding beam adjustment, program controlled - Central crowning device, motorized
Bottom beam	<ul style="list-style-type: none"> - Bottom beam blade, one-piece - Motorized bottom beam adjustment, program controlled
Others	<ul style="list-style-type: none"> - Piece counter - Tool set - Foot switch - All tools ca. 1100 N/mm²

Special equipment	
POS 2000 Professional options	<ul style="list-style-type: none"> - PC version (external programming), 1. licence - POS 3000 3D graphic control - DXF-Import and more processor capacity - Remote maintenance (connection via RJ45 network cable to be provided by customer)
Table and back gauge	<ul style="list-style-type: none"> - Sheet support table with balls 10 - 1000 mm or 10 - 1500 mm - POS 2000 Professional with gauge 10 - 1500 mm and 2 gauge sectors with pneumatic lowering device
	<ul style="list-style-type: none"> - Back gauge extension to U-gauge (U-shape 3200 or 4000 mm) - Basis: POS 2000 Professional 10 - 1000 mm - Configuration: Several gauge sectors with pneumatic lowering device, angle gauge, balls in table
Safety & Others	<ul style="list-style-type: none"> - Additional equipment for 2-man-operation control in accordance with accident prevention rules required - 2nd footswitch for operation from the rear - footswitch on rail for lateral movement - In addition for operation from the rear, access security in front via light barriers - Tool cart for blades, and segmented tools - Tool options, see page 7

POS 2000 Professional

Intelligent graphic control for efficient processing

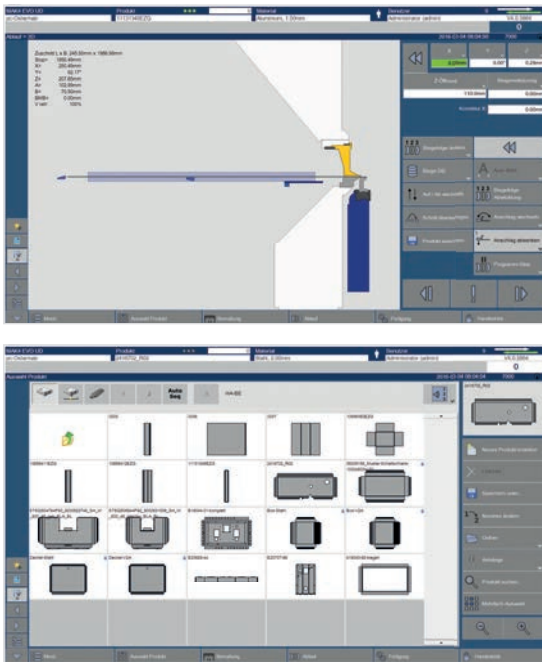

Graphic control POS 2000 Professional:
the result always in front of your eyes -
from the first steps to simulation

The MAK 4 owes its high processing speed, precision and efficiency to the powerful software control POS 2000 Professional with touchscreen mounted on a swivelling arm. This software is known in the industry as „the“ software control for folding machines - proven and fully developed .

The POS 2000 Professional visualizes every processing step - through it, the folding machine, work piece and tools are schematically shown. The product is confirmed in a virtual mode prior to putting the sheet on the back gauge table, so the operator can form the part with 100% confidence. All necessary actions such as turning a sheet are displayed in separate steps.

In short: Whether programming, running a simulation for a feasibility check or time study, or manipulating a part on the machine, the POS 2000 Professional supports your operation like no other can.



Highlights

- Windows 10 operating system
- Unlimited profile storage
- Automatic cut length calculation
- Unlimited tool storage and materials library
- Accurately scaled virtual bending simulation
- Zoom function
- Speed of CNC-axes infinitely variable

Options

- External programming
(POS 2000 Professional PC version)
- Remote maintenance

POS 3000 3D-graphic control

Visualize quality: POS 3000 3D-graphic control with simulation

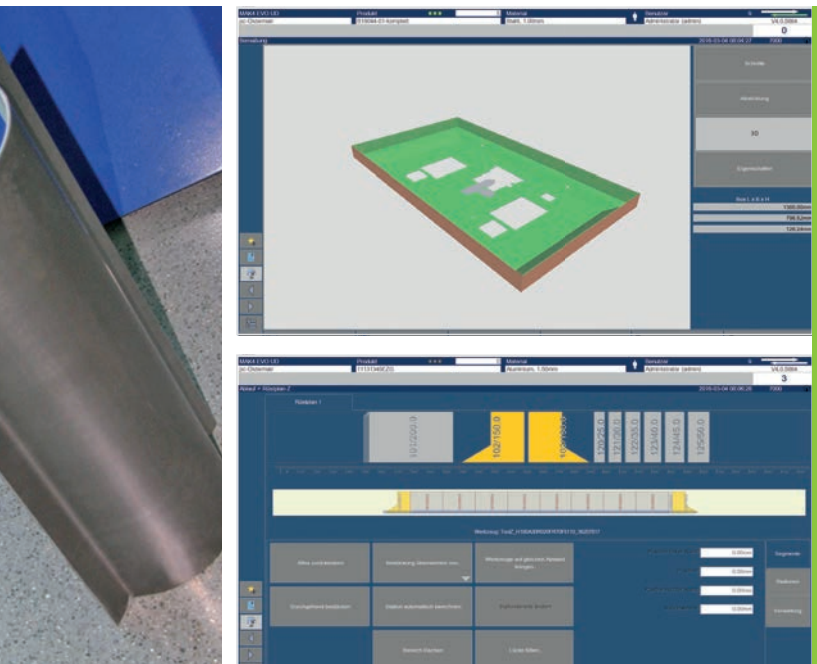

The easy to understand graphics present a clear visual interaction between the part, the machine and the tools. Sophisticated parts are easily understood.

The POS 3000 software control allows you to import DXF, BPX and GEO-files. Hence the most important product- and folding parameters can be imported automatically and without any intervention of the operator. Using this function, all shapes of a sheet can get displayed and the operator can choose between additional gauge options. This means substantial time savings and has the additional advantage that the operator does not have to program the workpiece that has to be bend.

With the POS 3000 software, the machine, tool, and work piece are all clearly displayed. The operator bends the part visually beforehand on the screen and checks the result in the 3D bending simulator. This ensures a perfect processing of the sheet. Once a bending program has been created they can be called up again quickly, checked visually, and corrected according to material requirements.



Highlights

- 3D-graphic control incl. schematic depiction of the machine, tools and work piece
- Intuitive, visual touchscreen-programming
- 3D-bending simulator for visual program inspection
- Cycle time calculator
- External programming (POS 3000 PC version)
- CAM-connection
- ERP/PPS-interfaces
- DXF, BPX and GEO-import
- Remote maintenance

Tools and technical data

For every task the suitable a tool – with the high-quality segmented tools from Schröder your are folding exactly and bend radii with highest precision.



MAK 4	3,200 x 6.0	4,000 x 5.0
Working length	3,220 mm	4,020 mm
Sheet thickness (400 N/mm ²)	6.0 mm	5.0 mm
Weight	8,880 kg	10,900 kg
Machine length (a)	5,310 mm	6,110 mm
Hole fixings (b)	3,870 mm	4,670 mm
Machine width POS 2000 Professional		
Back gauge, 1,000 mm		2,510 mm
Back gauge, 1,500 mm		2,500 mm
Back gauge, 3,200 mm		4,460 mm
Back gauge, 4,000 mm		5,320 mm
Standard colour	RAL 7035 light grey RAL 5003 sapphire blue	

Lowering of folding beam

All specifications are considered as guidelines and may be subject to change at any time.

Dimensions: MAK 4

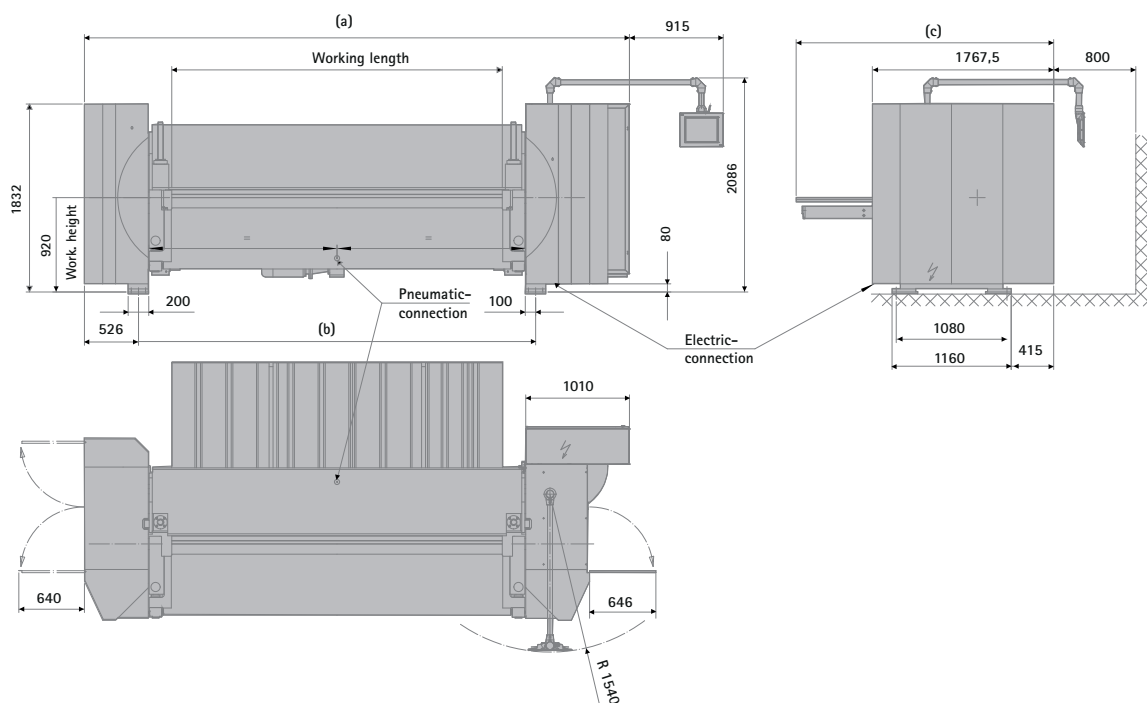

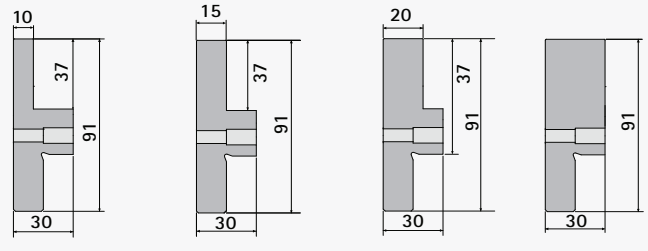
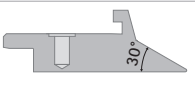
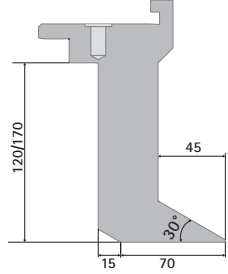
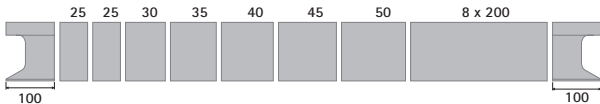
Tool options	
Folding beam tools (WZS* 3000), ca. 1100 N/mm ² surface-hardened (nitrated)	 <p>Folding blade, segmented 10/15/20/30 mm, 91 mm high, ca. 1100 N/mm²</p>
Clamping beam tools (WZS 2000), hydraulic tool clamping, ca. 1100 N/mm ² surface-treated (phosphated)	 <p>Sharp-nose blade 30°, R 1/1,5/3, divided</p>  <p>Goat's foot blade 120 or 170 mm high, 30°, R 1/1.5/3, foot width 85 mm, clearance 45 mm</p>  <p>Example: segmentation of a goat's foot tool for a working length of 2,040 mm (segmentation varies according to working lengths)</p>

Special configuration: extensions

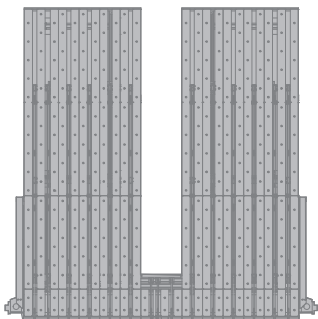

U-shape 3 200, 4 x 800 mm
 U-shape 4 000, 5 x 800 mm

All dimensions in mm

Standard colour: RAL 7035 light grey, RAL 5003 sapphire blue. Special painting at an extra charge



Schröder Group

The Schröder Group consists of Hans Schröder Maschinenbau GmbH, which is located in Wessobrunn, Germany, and SCHRÖDER-FASTI Technologie GmbH, which is located in Wermelskirchen, Germany.

Founded in 1949, Hans Schröder Maschinenbau GmbH unifies traditional and modern approaches in machine building: Successfully managed as a quality and customer-oriented, family-owned company, Hans Schröder Maschinenbau is specialized in the development of modern machine concepts for bending and cutting sheet metal.

The successful integration of the Fasti Company in 2006 and its worldwide presence make the Schröder Group one of today's leading providers of machines for bending, cutting, beading, flanging, and circular bending all types of sheet metal. The company's precision machines range from proven solutions for craftsmen to innovative, high-performance machines for automatic industrial production processes. Overall, the Schröder Group currently employs more than 270 people at various locations at home and abroad.

All information provided as a guide only
and subject to change at all times.
HSM 210426EN

Hans Schröder Maschinenbau GmbH
Feuchten 2 | 82405 Wessobrunn-Forst | Germany
T +49 8809 9220-0 | F +49 8809 9220-700
E info@schroedergroup.eu
www.schroedergroup.eu

SCHRÖDER
GROUP